

THIS DRAWING IS UNPUBLISHED. RELEASED FOR PUBLICATION
 © COPYRIGHT 19 BY AMP INCORPORATED. ALL RIGHTS RESERVED.

LOC		DIST		REVISIONS			
P	LTR	DESCRIPTION		DATE	DWN	APVD	
FT	60	A		REV & REDRAW ON CAD PER EC 0320-70-97	11 MAR 97	-	-

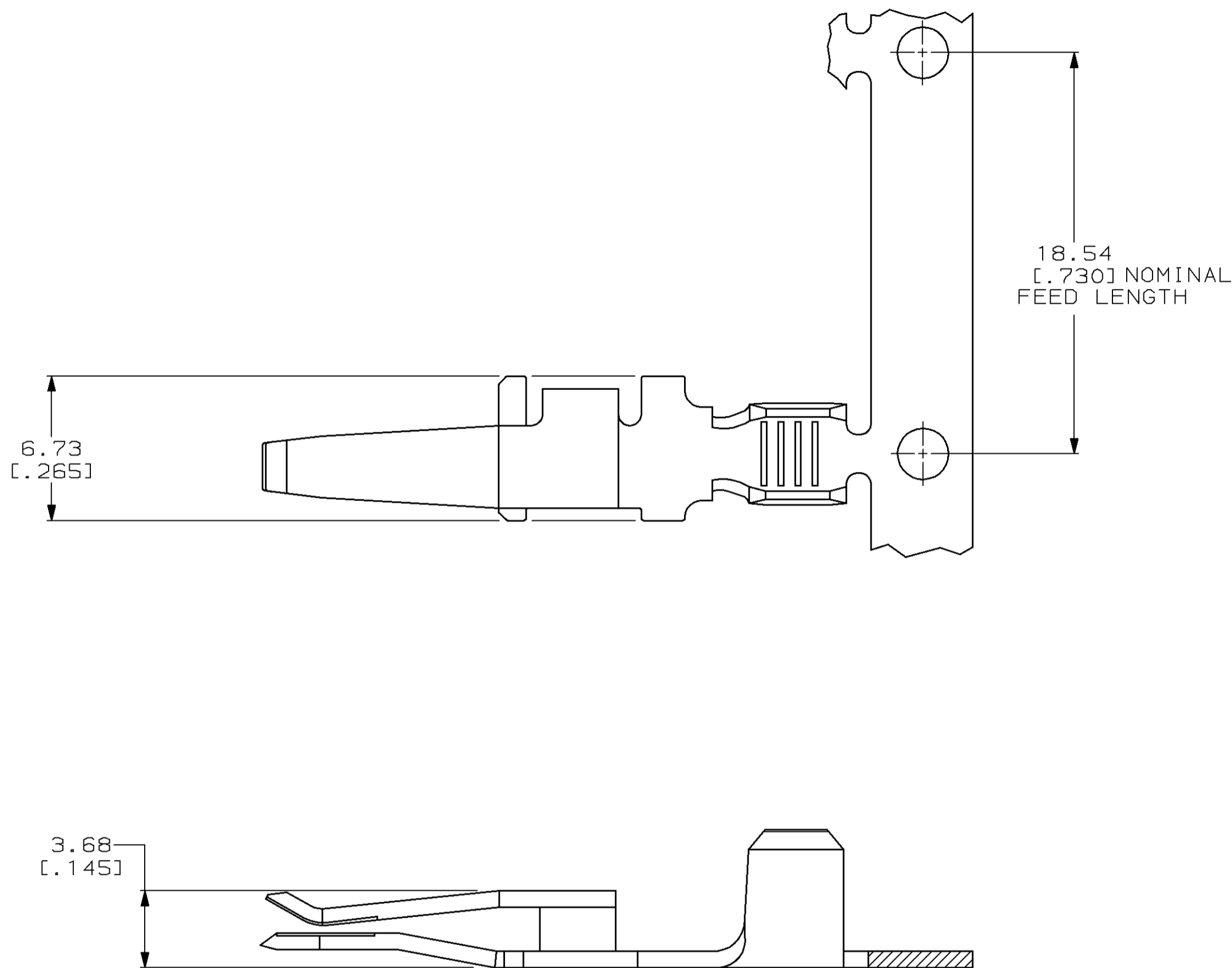

- ① ALL DIMENSIONS ARE MAXIMUM UNLESS OTHERWISE SPECIFIED.
- ② COPPER ALLOY.
- ③ 2.54µm [.000100] MIN TIN.
- 4. WIRE BARREL WILL ACCEPT ONE 10 OR 12 AWG STRANDED WIRE OR COMBINATIONS OF 12,18,16 AND 14 AWG WIRE.
- 5. THIS TERMINAL IS USED WITH HOUSING 556137 AND MOUNTING ADAPTER 557313-1.
- 6. APPLICATOR REEL: 567256-3 FOR "T" TERMINATOR, 567256-4 FOR AMP-O-ELECTRIC™ MODEL "K" MACHINE 565435-5.
- 7. HAND TOOL-LOOSE PIECE.

PACKAGING	DESCRIPTION	PART NUMBER
200 TERMINALS PER BOX	LOOSE PIECE	556136-2
2000 TERMINALS ON 24" DIA REEL	ON STRIP	556136-1

THIS DRAWING IS A CONTROLLED DOCUMENT.		DWN M. BINNER 11 MAR 97	AMP Incorporated Harrisburg, PA 17105-3608
DIMENSIONS: mm [INCHES]		CHK R. STONE 14 MAR 97	
TOLERANCES UNLESS OTHERWISE SPECIFIED:		APVD M. McALONIS 17 MAR 97	
0 PLC ±-	1 PLC ±-	PRODUCT SPEC	TERMINAL, 12-10 AWG, FOLDED CRIMP, WTW, AMPINERGY™
2 PLC ±-	3 PLC ±-	108-1373	
4 PLC ±-	ANGLES ±-	APPLICATION SPEC	SIZE
MATERIAL ②	FINISH ③	114-6051	A2
		WEIGHT -	CAGE CODE 00779
		CUSTOMER DRAWING	DRAWING NO. C-556136
		SCALE 5:1	SHEET 1 OF 1
			REV A